

DRYBACK INSTALLATION INSTRUCTIONS

EN / REV. 1.8 / 07.25

GENERAL INFORMATION AND PREPARATION

LASSEN Dryback must be installed in accordance with VOB, Part C DIN 18365 and the relevant national standards and guidelines. Please also observe the generally accepted rules of the trade and the current state of the art. In order to ensure maximum usability, serviceability and value retention of dryback floor coverings, proper subfloor preparation and handling of the required auxiliary building materials – such as primers, levelling compounds, underlays and adhesives – are critical.

Please follow the instructions and guidelines of the manufacturers of these materials.

For each type of material, use only products from the same manufacturer that are designed to work together as a system.

According to accepted technical regulations, the flooring installer/contractor must assess whether the subfloor meets the requirements for laying the dryback flooring before starting work. Any concerns must be communicated in writing.

APPLICATIONS

CLASSEN dryback floor coverings are ideal for installation in both domestic and commercial projects, whether for new construction or renovation. Installation outdoors or in saunas is not permitted.

STORAGE AND TRANSPORT

To avoid material deformation, transport and store the dryback planks on a level surface. The packages must never be stored vertically or in places with extreme temperatures.

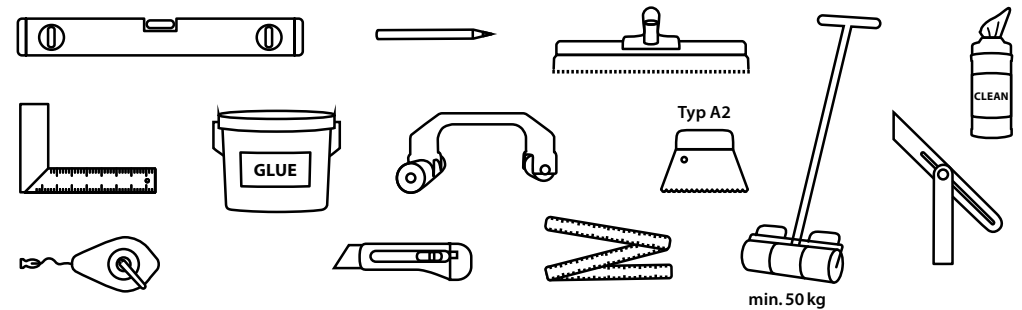

INSTALLATION TOOLS

Scale, pencil, angle, flooring knife with trapezoid or hook (concave) blade, chalk line, A2 notched adhesive spreader, hand pressure roller, segmented flooring roller weighing at least 50 kg, spirit level, cleaning cloths, squeegee.

ACCLIMATION

The flooring and auxiliary materials must be acclimated for at least 48 hours prior to installation. Store them in the rooms in which the flooring is to be installed at a temperature of <math>< 18^{\circ}\text{C}</math>. The dryback planks should be stacked as low as possible with no more than 4-5 packs per stack – or with criss-cross stacking. Care must be taken to ensure that the materials are not acclimated in direct sunlight.

Dryback planks can be bonded to all common subfloor types (cement screed, calcium sulphate screed, dry screed, chipboard constructions, ceramic tiles, raised floor constructions, etc.), as long as they are fundamentally suitable for the installation of elastic floor coverings. Exceptions include any textile and moisture-sensitive coverings, PVC coverings with foamed backing and laminate flooring.

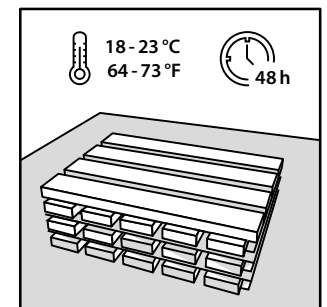

1. TESTING AND PREPARING THE SUBFLOOR

First remove the old flooring. The subfloor must be tested and prepared in accordance with VOB, Part C, DIN 18365 or the applicable standards for flooring work, the generally accepted rules of the trade and the state of the art.

Among other things, the subfloor must load-bearing, tension/compression-resistant, permanently dry, clean, free of dust, oil and grease, level, free of cracks, and rigid. Depending on the type of subfloor, make sure that any residual or rising moisture is at an acceptable level. The moisture content of the subfloors must not exceed 1.8 CM-% for cement screed and 0.3 CM% for anhydrite flowing screed.

Loose parts and non-waterproof coatings must be removed.

Flatness Deviations

The quality of the subfloor preparation has a significant influence on the outcome of the laid surface.

Absorbent subfloors and even surfaces are required for proper installation of floor coverings.

Flatness deviations of more than 3 mm / 2 m and sudden offsets of more than 0.2 mm must be filled or levelled. Old tile coverings always need to be specially prepared, with the entire surface levelled using a suitable filling compound.

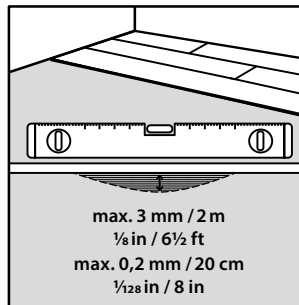
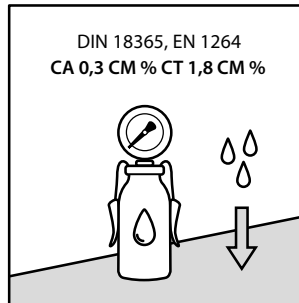
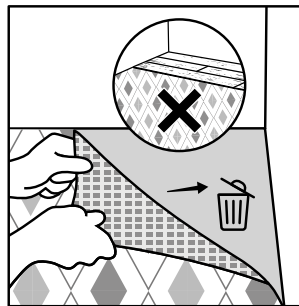

For the installation of dryback flooring, it is standard practice to apply a 2.0 to 3.0 mm thick layer of levelling compound with the spreader, followed by smoothing the surface with a spiked roller. Any remaining unevenness on the levelled floor must be removed after drying with a finishing spatula or a disc floor machine, followed by vacuuming the surface thoroughly.

Any remaining irregularities and unevenness can have a visible effect on the laid surface.

Joints

Movement joints must remain unhindered, with the floor covering laid accordingly.

Dummy joints (“construction joints” or “trowel cuts”) are treated like cracks and must be closed in a structurally bonded manner.

Joints in the edge area and adjacent components must be preserved in the surface covering and covered only with strips or elastic material to avoid restricting their functionality.

Installation on Underfloor Heating

CLASSEN dryback floor coverings are suitable for installing on underfloor heating.

In addition to DIN 18365, EN 1264-2 also applies to hot water underfloor heating systems. The surface temperature must not exceed 29 °C.

During installation, the underfloor heating must be kept at a surface temperature of 18 - 22 °C.

Only electric underfloor heating systems that are laid in the screed, ensure slow and even heating, and whose surface temperature cannot rise above 29 °C at any time are suitable for CLASSEN dryback floor coverings. A controlled pre-heating process, including the creation of a heating protocol, is required to prepare underfloor heating systems for installation.

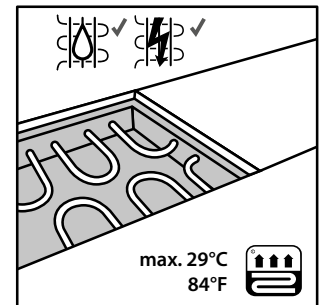
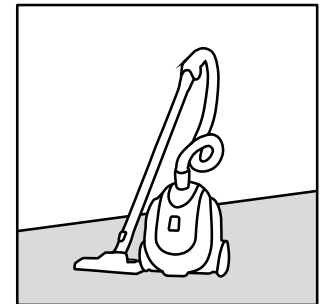
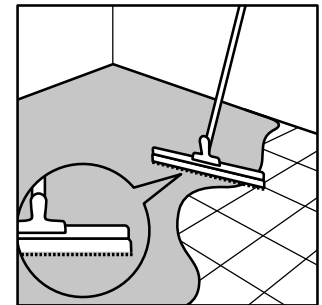

2. PREPARATION FOR INSTALLING CLASSEN

DRYBACK FLOORING

Dryback floor coverings and auxiliary materials (e.g., adhesives and levelling compounds) must be stored at an ambient air temperature of at least 18 °C, a floor temperature of at least 15 °C and a relative humidity of 30% to max. 75% for installation.

These climatic conditions must be maintained on site 3 days before starting the preparatory work, during installation, and up to 7 days after completion.

The climate conditions of the room need to remain constant during the setting phase of the adhesive.

High air temperatures can affect the reaction times and drying behaviour of the installation materials, leading to dimensional changes in the floor coverings.

Furniture should not be placed on the floor until the adhesive has set completely.

In order to guarantee a high standard of quality, our dryback coverings undergo a careful and regular quality control process.

Should material defects nevertheless occur on the construction site, they must be reported before cutting and laying the flooring, which must then not be used.

The coverings must be checked for detectable defects such as incorrect delivery quantity, transport damage, batch conformity, incorrect delivery type, any colour deviations, embossing errors, thickness deviations, etc. Within a production batch, minor colour deviations may occur and are acceptable.

Within one room unit, we recommend mixing individual planks/tiles from several packages, but please ensure that all of the elements installed in a room are from a single batch.

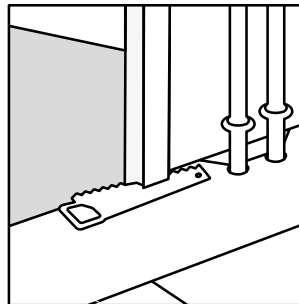
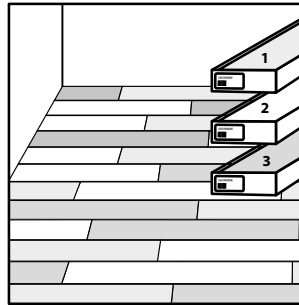
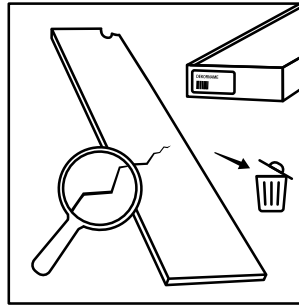

The last and first row of planks should be at least 8 cm wide. We recommend measuring and cutting the first rows first and laying them dry. Cut wooden frames to plank height and lay the floor covering under the frames. For steel frames, lay the dryback covering with a minimum joint of at least the same material thickness and seal the joint with a suitable natural stone silicone.

On heating pipes, work up to the insulation strips and cover the joint with a radiator rosette.

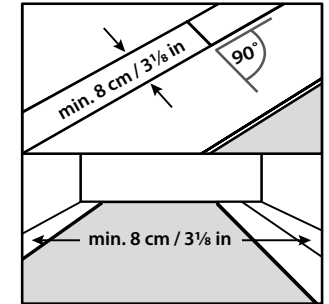

6. CUTTING CLASSEN DRYBACK COVERINGS

Dryback coverings are easy to cut to size. To do this, mark the planks and score the design surface with a design punch or a sharp-edged cutter knife (with a trapezoid or concave blade), using the edge of a ruler or an angle stop as a guide. Then bend the plank at the cut edge. Caution: The cut edge may be sharp.

Measure the rooms to optimise the layout and determine align the first rows using a string.

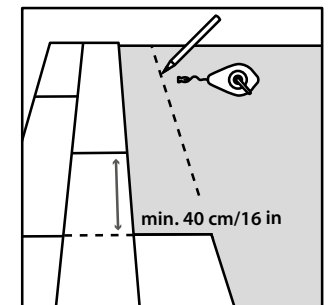
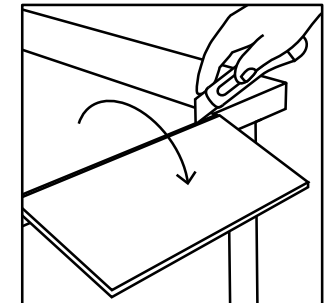

4. SELECTING THE ADHESIVE AND SPREADER

Full-surface bonding is mandatory in all installation areas. Be sure to use CLASSEN MultiConnect or one of the other recommended adhesives to bond the dryback coverings, taking care that the adhesive is applied evenly and using the specified spreader notch size.

PU/SMP or EP adhesives are recommended for use in rooms with increased humidity, surface moisture or greater thermal loads. Go to www.classengroup.com/downloads for a table of recommended adhesives. Please observe the manufacturer's instructions for use.

TIP: Material and processing conditions can influence the adhesive behaviour in different ways, so we recommend testing beforehand.

Please note: While we recommend a selection of adhesives from various other manufacturers in addition to CLASSEN MultiConnect, we accept no warranty or liability for the products listed.

The adhesive recommendation is based entirely on statements made by the respective manufacturer, which is also solely responsible for the product's suitability. For further information on suitability, please contact the adhesive manufacturer's customer service.

Use a notched spreader that meets the adhesive manufacturer's recommendation. We recommend a type A2 notched spreader to prevent adhesive grooves from appearing on the top of the floor covering.

TIP: Do not use worn-out spreaders.

5. APPLYING THE ADHESIVE

The adhesive is applied to the subfloor using a notched spreader. The subfloor should be sufficiently covered by the adhesive to ensure full-surface contact between the adhesive and the subfloor.

Ensure that the adhesive is evenly distributed and that the grooves are clearly visible. Hold the notched spreader at an angle of approx. 60° and avoid clumps of adhesive.

Only apply as much adhesive as you can process within the time available. Draw a marking line along the dry-laid row and apply the adhesive up to this marking.

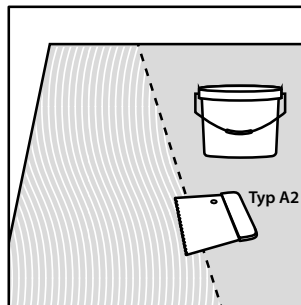

NOTE: Temperature and humidity fluctuations can significantly change the available amount of time.

6. BONDING THE DRYBACK PLANKS

Lay the planks stress-free and joint-tight without any airing time into the wet adhesive bed. Make sure that the first rows are perfectly aligned along the line and check the alignment at regular intervals using a string. This is the best way to ensure that you are laying the planks parallel and at right angles. Avoid a wedge-shaped opening at the joints on the front side of the planks at all costs.

When gluing wood decor designs in an irregular bond (wild bond), the strips are randomly offset in each row, and a minimum or joint offset of twice the panel width is maintained to prevent the end joints from forming a line. Tile designs are often laid in an English pattern (centre offset) for aesthetic reasons.

Be sure to press the individual planks against each other using only light pressure to avoid subsequent joint formation.

Any adhesive residue that escapes from the joint should be carefully removed right away using special cleaning cloths.

Press the planks down immediately over the entire surface using the hand pressure roller. Care must be taken to ensure that the adhesive is carefully applied to the entire surface of the flooring underside.

After a waiting time of approx. 30 - 45 minutes, depending on the adhesive system, temperature, and humidity, go over the floor covering again with the segmented roller (at least 50 kg) to ensure that the adhesive grooves are completely crushed and the underside of the covering is sufficiently covered with the adhesive. This will prevent the adhesive from being pressed down and causing indentations during later use.

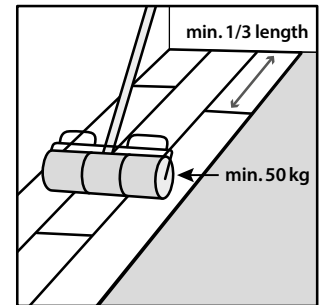
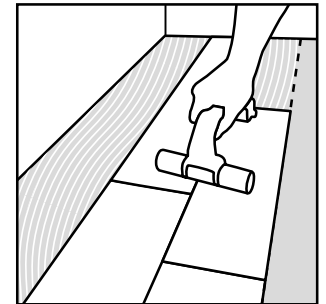
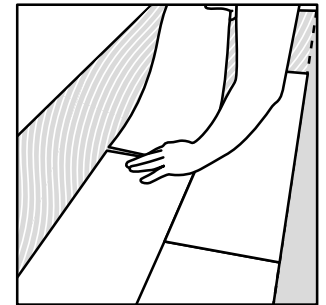

7. COMPLETION

The expansion joint on the wall is covered with skirting boards. Alternatively, in damp spaces (such as bathrooms), the expansion joints can be filled using an inserted PE round cord and a natural stone silicone joint applied on top to preserve the movement of the floor and the structure. Make sure to use suitable adhesives when installing in wet areas!

8. CLEANING / CARE / VALUE RETENTION

Wait at least 4 hours before walking on the freshly laid dryback floor. The adhesive must be cured before you place furniture on the floor. Depending on the adhesive system and the climatic conditions, the floor should not be subjected to loads for at least 24 hours.

Do not moisten or clean with water until after at least 72 hours. Never use a steam cleaner. Observe the authoritative and binding specifications of the respective adhesive manufacturer with regard to the curing time and load specifications.

Your CLASSEN dryback flooring can be easily cleaned with any commercially available, non-film-forming cleaning agent for design flooring. Aggressive cleaners (e.g., those containing chlorine), abrasive scouring agents or steel wool must never be used. Remove any greasy residues as quickly as possible, since they will be more difficult to remove later. By removing any water residues promptly, you will avoid the formation of lime deposits

TIP: Test the cleaning agent on a less visible area beforehand to check its effectiveness and compatibility.

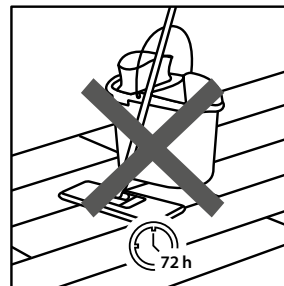
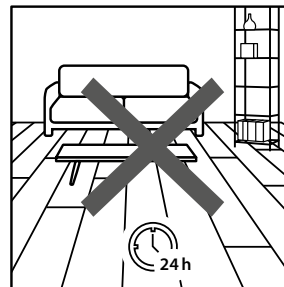
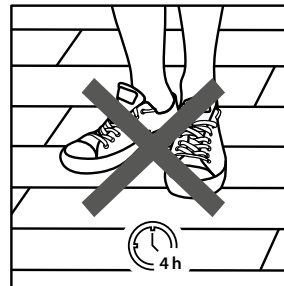

The following minimum distances must be observed when installing fireplaces or tiled stoves: at least 50 cm to the front and at least 20 cm to the side.

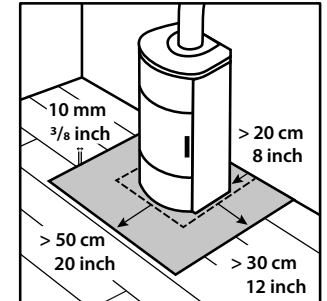

Office chairs must be fitted with type W soft casters in accordance with EN 12529 (double swivel casters). We also recommend the use of suitable office chair mats.

Furniture and chair legs must be fitted with felt glides of the appropriate size. Never place flower pots directly on the flooring

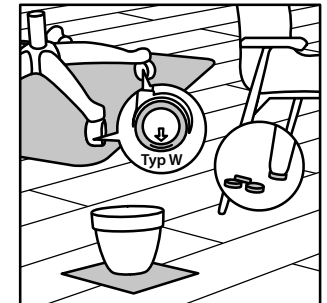

Please make sure that there are adequate floor mats for wiping shoes in front of and behind the entrance door as well.

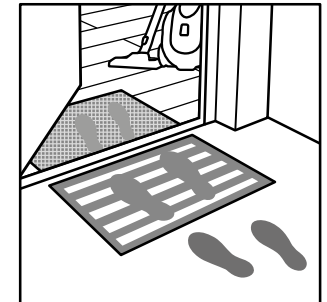

DISCLAIMER

These installation instructions have been prepared to the best of our knowledge and with particular care. The details are based on practical experience and our own tests and corresponds to our current state of knowledge at the time of publication. They are for informational purposes only and do not constitute a guarantee of product characteristics or suitability for specific purposes. We assume no liability for any printing errors, errors in standards or other mistakes. In addition, technical changes may result at any time from the continuous development of the products we produce and from changes to standards and public law documents. However, we cannot guarantee the installation result in each case due to the large number of possible applications (a complete list of which would be impossible) and because the conditions of storage, installation and construction sites are beyond our control.

The publication of this edition renders all previous editions invalid. Before use, please be sure to check our website at **www.classengroup.com** for any updates.

Please follow the instructions for installation and care: **www.classengroup.com/downloads**
This product can be disposed of with normal household waste.

The guarantee against abrasion is in accordance with CLASSEN guarantee conditions.

If you have any complaints, please indicate the production code provided on the label at the top of the box!

For more information, visit us at **www.classengroup.com**

If you have any questions about the product or processing, please contact our technical customer service hotline: **0800 1133313**.

If you have any questions regarding the suitability of third-party adhesives, please contact the adhesive manufacturer's customer service.



CLASSEN Holz Kontor GmbH
Werner-von-Siemens- Str. 18–20
DE 56759 Kaisersesch
www.classengroup.com
info@classen.de

**Intellectual
Property Rights:**

